

COMBICOM



InterBus-Operator

Version 7.1

1	General	3
1.1	Product Description.....	3
1.2	Definitions	3
1.3	Technical Data.....	3
2	Communication Interface (PCP)	4
2.1	Communication Relation List.....	4
2.2	Object Directory.....	4
2.3	Error Codes of the PCP-Channel.....	8
3	Process Data Channel	9
4	IO-Mode	10
4.1	Error Codes in the IO-Mode.....	11
4.2	Reading a Parameter in the IO-Mode	11
4.3	Writing a Parameter in the IO-Mode (16-Bit Data Length).....	11
4.4	Writing a Parameter in the IO-Mode (32-Bit Data Length).....	12
4.5	Write with Synchronization in the IO-Mode.....	12
5	Diagnostic Interface	12
6	Operation	14
6.1	Diagnostic Elements	14
6.2	Connector Pin Assignment.....	15
6.3	Installation.....	15

1 General

The documentation as well as the hardware and software are developments of the Karl E. Brinkmann GmbH. Errors and omissions excepted! The Karl E. Brinkmann GmbH has prepared the documentation, software and hardware to the best of their knowledge, but no guarantee is given that the specifications will bring the user the efficiency aimed at.

The Karl E. Brinkmann GmbH reserves the right to change the specifications without obligation. All rights reserved!

This instruction manual describes the software standard from 12/2003.

1.1 Product Description

The described module is a plug-on operator with InterBus 2-wire remote bus interface board for the frequency inverter KEB COMBIVERT F5. The voltage supply takes place via the frequency inverter and for independent supply it can also be fed externally over the terminal strip of the inverter. Over the PCP-channel 0, 1, 2 or 3 hardware InterBus register words can be configured for the process data channel. Parallel to the field bus operation the operation via the integrated display/keyboard as well as a further serial interface for diagnosis/parameterizing (KEB COMBIVIS) is possible.

1.2 Definitions

PCP (Peripheral Communication Protocol)

Serves for reading/writing of all objects via the communication interface.

Process data Out (PD Out)

Fast input of data from the control to the inverter without addressing. The target parameter in the inverter has been defined beforehand.

Process data In (PD In)

Cyclic reading of data from inverter to control. The source parameter in the inverter has been defined beforehand.

Host

InterBus-Master, e.g. PLC with InterBus-controller board, PC with InterBus-card, etc.

1.3 Technical Data

Communication-capable InterBus-module on 2-wire remote bus, supports one communication word and 0...3 process data words.

IB-2-wire remote bus	RS485
IB-ID-Code	227
Input IB_in	SUB-MIN-9pole-MALE, DIN 41652 Part 1
Output IB_out	SUB-MIN-9pole-FEMALE, DIN 41652 Part 1
Voltage supply	via the inverter
Isolation	500 VDC between InterBus input and output interface
Housing	Standard F5 Operator, pluggable
Operating temperature	-10° to 45° Celsius
Part number	00.F5.060-4000 (500 KBaud InterBus) 00.F5.060-4001 (2 MBaud InterBus)

2 Communication Interface (PCP)

After bus start the connection from the host to the operator is established by way of the service 'Context Management Initiate'. The connection is not aborted independently by the operator. On executing the service 'VFD Support Identify' the operator identifies himself with manufacturer-specific data. All parameters of the inverter are readable via the service 'Variable Access Read'. The operating parameters are writable via the service 'Variable Access Write'. A capsulation of the HSP5 services is available over the service 'Variable Access Information Report'.

2.1 Communication Relation List

The communication relation list of the operator contains following entries:

Communication reference: 2

Physical address = 0 (Host)

Max. number of outstanding client services = 1

Max. number of outstanding server services = 1

Max. PDU-length Request/Response = 64 Byte

Max. PDU-length Indication/Confirmation = 64 Byte

Supported services as client = Information-Report

Supported services as server = Read, Write and Information-Report

2.2 Object Directory

2000h...5FEFh KEB Object

Length: 1, 2 or 4 Bytes

Access to parameters of the frequency inverter, Parameter address = Index - 2000h

Subindex = 0 indirect set addressing

Subindex > 0 = Subindex is desired set identifier (bit by bit)

Read: It always returns 4 bytes (Long)

Write: Data is sign-extended internally to 32 bits (1 Byte as FFh or 2 Bytes as FFFFh => -1)

5FF7h Additional Control Word

Length: 2 Bytes

When using the Drivecom-control word (6040h) it serves for the additional setting of bits in the inverter / servo parameter SY.50. At this the bits 3...7 and 9...15 are masked in directly. Thus further functions (set selection/operating modes etc.) can be used over SY.50.

5FF8h Synchronous time

Length: 1, 2 or 4 Bytes

Resolution: 1 us

Switches into the synchronous operation and defines the cycle time. By writing a value of 0 it is switched back into the non-synchronous operation.

Read: Always returns 4 bytes (long).

Write: Data are internally sign-extended to 32 bit (1 byte as FFh or 2 bytes as FFFFh => -1).

Depending on the inverter/servo type only integral 1000 us-values are possible.

Note: The synchronous operation is not supported by all inverter/servo types. In the synchronous mode the keyboard/display is switched off and shows 'Synch'. The access to inverter parameters over the diagnostic interface can occur only by means of indirect set addressing (service 1). The use of the IO-mode is not possible. The process data handshake is not masked in. Maximally a 32-bit plus a 16-bit parameter, whereby the 32-bit parameter must be put onto the 1.PD-word, or three 16-bit parameters can be configured for process data. Independent of the adjusted time, an activated InterBus reset monitoring (see object 5FF9h) leads to the immediate switch-off of the inverter/servo.

Attention: The InterBus data cycles must constantly be transmitted in step with the cycle time. If the used Interbus master is not capable of this, especially in position mode there can be large position shifts in the servo axes. Your supplier of the interbus master will provide you with informations about this.

5FF9h Watchdog inhibit

Length: 1 Byte

Activates or deactivates the different Watchdog-reset functions. Serves in connection with the frequency inverter bus watchdog setting for a defined stopping of the frequency inverter in case of an error.

Write: Index = 5FF9h; Subindex = 0; DATA= 0000dcba (binary)

a = 1 -> PD-Out value changes reset the watchdog time (not in synchron mode)

b = 1 -> PCP-communication resets the watchdog time

c = 1 -> InterBus OK resets the watchdog time, InterBus Reset counts
down the time (synchron immediately)

d = 1 -> InterBus data cycles reset the watchdog time

A value of 0 deactivates the corresponding function (no influence on watchdog).

If the watchdog time is not reset by an activated function before expiration then the stop function adjusted at the inverter takes effect.

Note: If more than one function is activated then the watchdog function is already reset by ONE correct function and the inverter is NOT stopped.

5FFAh Handshake enable

Length: 1Byte

Activates or deactivates the process data handshake bit. On activation the most significant bit in the 1. process data word IN is changed each time, when all active process data OUT have been transferred to the inverter. This enables the fastest possible process data setting of new values.

Write: Index = 5FFAh; Subindex = 0; Data = FFh -> activating handshake bit

Write: Index = 5FFAh; Subindex = 0; Data = 00h -> deactivating handshake bit (default value)

Read: Index = 5FFAh; Subindex = 0 -> Data = 00h : deactivated -> Data = FFh : activated

Note: When activated the most significant bit in the 1. process data word IN is NOT part of the process data value (bit must be masked out).

5FFBh HSP5-Object

Length: min. 4 Bytes, depending on the HSP5-service

To be reached only via PCP Information Report Request.

Over this object complete HSP5-telegrams can be sent or received.

For that purpose a PCP Info_Report_Request with index 5FFBh, subindex 0 is written.

The desired HSP5-telegram is entered as data.

As response telegram a PCP Info_Report_Response is sent back by the operator, likewise with the HSP5-response as data.

All information to HSP5 are found in the HSP5-protocol description.

5FFCh Store Settings

Length: 1 Byte

With this object all settings of the objects 5FF9, 5FFA and 5FFEh up to 6002h or their default values can be stored non-volatile.

Write: Index = 5FFCh; Subindex = 0; Data = FFh -> all settings are stored

Write: Index = 5FFCh; Subindex = 0; Data = 00h -> default values are stored

Read: Index = 5FFCh; Subindex = 0 -> Data = 00h : default values are stored

Note: The default values or a new process data length become active only after Power-On or bus reset.

5FFDh IO-Mode Object

Length: 2 Bytes

This object cannot be addressed via Read/Write, it serves only for the process data assignment. If this object is put on the 1. process data word OUT, then the process data IO-mode is activated after PD-Out enable (6002h). At the IO-Mode the parameter address and 16- or 32-bit parameter data are written via PD-Out or read via PD-IN, see chapter IOMode.

InterBus Operator

5FFEh PD-In enable

Length: 1 Byte

Activates/deactivates the process data IN-processing. The content of deactivated process data IN-registers is purely accidental. The activation/deactivation takes place immediately after the writing.

Write: Index = 5FFEh; Subindex = 0; DATA 000c0b0a (binary)

a=1 -> activate 1.PD-Word IN; a=0-> deactivate

b=1 -> activate 2.PD-Word IN; b=0-> deactivate

c=1 -> activate 3.PD-Word IN; c=0-> deactivate

All other bits are ignored.

Read: Index = 5FFEh; Subindex = 0; DATA 00ccbbaa (binary); Default value = 00001111(binary)

a=1 -> 1.PD-Wort IN is active; a=0 -> deactive

b=1 -> 2.PD-Wort IN is active; b=0 -> deactive

c=1 -> 3.PD-Wort IN is active; c=0 -> deactive

Note: The number of the actually used IN-words also depends on object 5FFFh.

5FFFh PD_Length

Length: 1 Byte

Defines the physical number of process data words (IN and OUT equally). The change of the physical register length becomes active after the next InterBus-Reset. **Attention:** this results in a change of the InterBus set-up!

Write: Index = 5FFFh; Subindex = 0;

DATA = 0, 2, 4 or 6 = Number of process data bytes (2 bytes = 1 Word); default value = 04h

Read: Index = 5FFFh; Subindex = 0;

-> DATA = 0, 2, 4 or 6 = Number of process data bytes (2 bytes = 1 Word)

6000h PD_In_Definition

Length: maximum 19 Bytes

Record with following set-up, set definitions are bit-coded.

Subindex	Length	Description	Default value
1	1 Byte	PD_Length	04h (not changeable)
2	1 Word	Index PD_In_1	2033h (SY51 Status word)
3	1 Byte	Set PD_In_1	01h (Set 0)
4	1Word	always 0000h	
5	1 Byte	always 00h	
6	1 Word	Index PD_In_2	2035h (SY53 Actual speed)
7	1 Byte	Set PD_In_2	01h (Set 0)
8	1 Word	always 0000h	
9	1 Byte	always 00h	
10	1 Word	Index PD_In_3	2000h
11	1 Byte	Set PD_In_3	01h (Set 0)
12	1 Word	always 0000h	
13	1 Byte	always 00h	

With this object the assignment of the IN-process data register can be adjusted or read. According to the profile DRIVECOM each process data byte must be configurable, but only the high bytes are changeable, since both process data bytes are always needed for one PD-word. In the following subindex the set access is specified bit-coded (1 = set 0; 4 = set 2, etc.). Here only a single set can be parameterized. By writing the IN-process data processing is locked immediately and becomes effective only after the release of the appropriate PD-word over object 5FFEh. The element 1 (PD_Length) shows the current physical process data register length and cannot be changed here (see object 5FFFh). The value 0 in an index definition means that a 32-bit parameter is on two neighbouring process data words. Value FFFFh switches off this process data assignment (see example process data assignment).

Write: Index = 6000h; Subindex = 2;

DATA = xxxh -> Index xxxh is placed on the 1. process data word IN.

Write: Index = 6000h; Subindex = 6;

DATA = xxxh -> Index xxxh Index xxxh is placed on the 2. process data word IN.

Write: Index = 6000h; Subindex = 10;

DATA = xxxh -> Index xxxh is placed on the 3. process data word IN.

Note: The number of the actually used IN-words also depends on object 5FFFh.

6001h PD_Out_Definition

Length: maximum 19 Bytes

Recording with following set-up, set definitions are bit-coded.

Subindex	Length	Description	Default value
1	1 Byte	PD_Length	4 (not changeable)
2	1 Word	Index PD_Out_1	2032h (SY50 Control word)
3	1 Byte	Set PD_Out_1	01h (Set 0)
4	1 Word	always 0000h	
5	1 Byte	always 00h	
6	1 Word	Index PD_Out_2	2034h (SY52 Setpoint speed)
7	1 Byte	Set PD_Out_2	01h (Set 0)
8	1 Word	always 0000h	
9	1 Byte	always 00h	
10	1 Word	Index PD_Out_3	2000h
11	1 Byte	Set PD_Out_3	01h (Set 0)
12	1 Word	always 0000h	
13	1 Byte	always 00h	

With this object the assignment of the OUT process data register can be adjusted or read. According to the profile DRIVECOM each process data byte must be configurable, but only the high bytes are changeable, since both process data bytes are always needed for one PD-word. In the following subindex the specified set access is bit-coded (1 = set 0; 4 = set 2, etc). Several sets are possible at the same time.

By writing on this object all process data OUT-words are deactivated and must be released again with object 6002h (after correct setting of the process data values). The element 1 (PD_Length) shows the current physical process data register length and cannot be changed here (see object 5FFFh). The value 0 in the index definition means that a 32-bit parameter is on two neighbouring process data words. Value FFFFh switches off this process data assignment (see example process data assignment).

Write: Index = 6001h; Subindex = 2;

DATA = xxxh -> Index xxxh is placed on the 1. process data word OUT.

Write: Index = 6001h; Subindex = 6;

DATA = xxxh -> Index xxxh is placed on the 2. process data word OUT.

Write: Index = 6001h; Subindex = 10;

DATA = xxxh -> Index xxxh is placed on the 3. process data word OUT.

Note: The number of actually used OUT-words also depends on object 5FFFh.

6002h PD-Out enable

Length: 1 Byte

Activates/deactivates the process data OUT processing. Deactivated PD-Words are ignored by the inverter. The activation/deactivation takes place immediately after the writing.

Write: Index = 6002h; Subindex = 0;

DATA 000c0b0a (binary)

a=1 -> activate 1.PD-Word OUT; a=0 -> deactive

b=1 -> activate 2.PD-Word OUT; b=0 -> deactive

c=1 -> activate 3.PD-WorD OUT; c=0 -> deactive

All other bits are ignored.

Read: Index = 6002h; Subindex = 0;

DATA 00ccbbaa (binary); Default value = 00001111(binary)

a=1 -> 1.PD-Word OUT is active; a=0 -> deactive

b=1 -> 2.PD-Word OUT is active; b=0 -> deactive

c=1 -> 3.PD-Word OUT is active; c=0 -> deactive

Note: The number of actually used OUT-words also depends on object 5FFFh.

6040h Control Word

Length: 2 Bytes

Control word according to Drivecom-Profile 21/22. The internal pre-setting is done over the inverter/servo parameter SY.50.

6041h Status Word

Length: 2 Bytes

Status word according to Drivecom-Profile 21/22.

6042h Setpoint Value

Length: 2 Bytes

Speed setpoint value according to Drivecom-Profile 21/22. Is mapped directly onto the inverter/servo parameter SY.52.

6044h Actual Value

Length: 2 Bytes

Speed actual value according to Drivecom-Profile 21/22. Is formed from the inverter/servo parameter SY.53.

2.3 Error Codes of the PCP-Channel

Error Class	Error Code	Code Add.	Significance
6=ACCESS	2=HARDWARE_FAULT	0	No response from the inverter
6=ACCESS	3=OBJ_ACCESS_DENIED	0	Object/Parameter write- or read-protected
		30h	Invalid password
6=ACCESS	4=ADDR_INVALID	0	Parameter non-existing
6=ACCESS	5=OBJ_ATTR_INCONSIST	10h	Data length too long or too short
		11h	Wrong subindex
		14h	No free buffer
6=ACCESS	6=ACC_UNSUPP	0	Object access denied
6=ACCESS	7=OBJ_NON_EXIST	0	Object non-existing
6=ACCESS	8=TYPE_CONFLICT	0	Invalid data type
8=OTHER	0=OTHER	22h	Inverter busy
		30h	Invalid data
		33h	Invalid set selection
		34h	Operation not possible
		41h	Process data assignment not possible
		10h	Invalid function

3 Process Data Channel

The number of process data words is adjustable between 0 and 3 words by means of object 5FFFh. This change must be stored (object 5FFCh) and is activated only after Power-On. When changing only one process data value OUT all active process data are transferred again to the inverter. Only then new PD-Out values are accepted. Whether a process data word is active depends on the adjustment of the process data length (object 5FFFh) and the process data activation (object 5FFEh for the IN-process data and object 6002h for the OUT-process data).

Example: Reassignment of Process Data Channel

The process data length shall be adjusted to 3 words.

PD-IN-assignment: KEB-parameter addresses 0200h, 0207h and 0208h (from the respective App. Manual).

PD-OUT-assignment: KEB-parameter addresses 0301h and 0302h (with 32 Bit data length).

All IN-parameters in Set 0, OUT-parameters in all sets.

1. Adjustment of PD-register length

Write: Index = 5FFFh; Subindex = 0; DATA = 06h -> 6 Bytes (3 Words) process data length

2. Adjustment of PD-IN-assignment

Write: Index = 6000h; Subindex = 2; DATA = 2200h-> KEB-Parameter 0200h (Index=2200h)

Write: Index = 6000h; Subindex = 3; DATA = 01h -> Set 0

Write: Index = 6000h; Subindex = 6; DATA = 2207h-> KEB-Parameter 0207h (Index = 2207h)

Write: Index = 6000h; Subindex = 7; DATA = 01h -> Set 0

Write: Index = 6000h; Subindex = 10; DATA = 2208h-> KEB-Parameter 0208h (Index = 2208h)

Write: Index = 6000h; Subindex = 11; DATA = 01h -> Set 0

or write entire object at once:

Write: Index = 6000h; Subindex = 0; Len = 19 Bytes

DATA = 00h, 2200h, 01h, 0000h, 00h, 2207h, 01h, 0000h, 00h, 2208h, 01h, 0000h, 00h

3. Adjustment of PD-OUT-assignment

Write: Index = 6001h; Subindex = 2; DATA = 2301h-> KEB-Parameter 0301h (Index = 2301h)

Write: Index = 6001h; Subindex = 3; DATA = FFh -> Set 0, 1, 2, 3, 4, 5, 6 and 7

Write: Index = 6001h; Subindex = 6; DATA = 2302h-> KEB-Parameter 0302h (Index = 2302h)

Write: Index = 6001h; Subindex = 7; DATA = FFh -> all Sets

Write: Index = 6001h; Subindex = 10; DATA = 0000h-> Low-Word from parameter 0302h

Write: Index = 6001h; Subindex = 11; DATA = 01h -> designate only one valid value (is not being used)

or write entire object at once:

Write: Index = 6001h; Subindex = 0; Len = 19 Bytes

DATA = 00h, 2301h, FFh, 0000h, 00h, 2302h, FFh, 0000h, 00h, 0000h, 01h, 0000h, 00h

4. Enabling of PD-IN-processing

Write: Index = 5FFEh; Subindex = 0; DATA = 3Fh -> enable PD-IN 1...3

5. Enabling of PD-OUT-processing

Write: Index = 6002h; Subindex = 0; DATA = 3Fh -> enable PD-OUT 1...3

6. Storing of all adjustments

Write: Index = 5FFCh; Subindex = 0; DATA = FFh -> store!

If the physical register length (object 5FFFh) was changed, then an InterBus reset is necessary. Otherwise the desired parameters are immediately processed by process data.

4 IO-Mode

To activate the IO-Mode put the object 5FFDh on the 1. process data word OUT and activate it. The IN-process data are configured automatically and should not be changed again manually.

Activation with 16-Bit parameter data:

Write: Index = 6001h; Subindex = 2; DATA = 5FFDh -> IO-Object

Write: Index = 6001h; Subindex = 6; DATA = 0000h -> 2. part of the IO-object

Write: Index = 6001h; Subindex = 10; DATA = FFFFh -> disabled

Write: Index = 6002h; Subindex = 0; DATA = 0Fh -> enable PD-OUT 1...2, PD-IN are also activated.

Activation with 32-Bit parameter data:

Write: Index = 6001h; Subindex = 2; DATA = 5FFDh -> IO-Object

Write: Index = 6001h; Subindex = 6; DATA = 0000h -> 2. part of the IO-Object (Data HighWord)

Write: Index = 6001h; Subindex = 10; DATA = 0000h -> 3. part of the IO-Object (Data LowWord)

Write: Index = 6002h; Subindex = 0; DATA = 3Fh -> enable PD-OUT 1...3, PD-IN are also activated.

These setting requires a physical process data length of 3 words.

In the IO-Mode all inverter parameters can be read or written by way of process data. For that the following meaning is defined for the IN-data (from the inverter) as well as the OUT-data (to the inverter):

In the 1. word OUT the parameter address in the range of 0...7FFFh and in the highest bit the write/read identification (R/W 0 = read; 1 = write) is entered. The address 0000h is the IDLE address. At this address no parameter is read or written. This is the basic state after reset on the InterBus. The identification 4B45h appears in the 2. word IN.

In the 2. word OUT (and at 32-Bit data length also in the 3. word OUT) the parameter data is entered during writing. At reading the value is optional.

In the 1. word IN the parameter address in the range of 0...7FFFh as well as in the highest bit an error identification (ERR 0 = OK; 1 = error) appears after a write or read process.

In the 2. word IN (and at 32-Bit data length also in the 3. word IN) the parameter data (ERR = 0) or an error code (ERR = 1, see section error codes) appears after a write or read process.

When writing parameters the parameter data must be written to the InterBus in the same cycle as the parameter address. If this is not ensured then for reasons of synchronization the IDLE-address 0000h must be written between different parameter addresses (see writing with synchronization).

All write and read processes are executed with indirect set addressing.

4.1 Error codes in the IO-Mode

Following error codes are defined:

Code	Error message	Description
1	No Answer	Inverter is switched off
2	Invalid Address/Password	Invalid parameter address or parameter password-protected
3	Invalid Data	The parameter value is invalid
4	Read Only	The addressed parameter is write-protected
5	BCC Error	Transmission error between operator and inverter
6	Inverter Busy	The inverter cannot receive data in this moment
7	Service not supported	Service is not supported
8	Invalid Password	Parameter password-protected
9	Invalid Frame	Invalid telegram between operator and inverter
10	Parity Error	Transmission error between operator and inverter
11	Invalid set selection	Invalid set selection
12	Invalid language	Invalid language selection
13	Invalid Address	Invalid parameter address
14	Invalid operation	Service cannot be executed in the current state

4.2 Reading a Parameter in the IO-Mode

The parameter with the address 2101h shall be read by the inverter.

The data length is adjusted to 16 Bit.

For that the OUT-data words are set as follows:

OUT1 = 2101h, OUT2 = optional

After the data from the inverter is available, the IN-data words change to:

IN1 = 2101h (parameter address), IN2 = 0044h (parameter data)

In case of error the highest bit is set in the 1. IN-word, in the 2. IN-word is the error code:

IN1 = A101h (parameter address + error bit), IN2 = 0002h (error 2: invalid address)

The addressed parameter is constantly read by the inverter and the newest value appears automatically in the 2. IN-word.

Note: In case of 32-Bit parameter data IN2 and IN3 are to be used as signaffected 32-Bit value.

4.3 Writing a Parameter in the IO-Mode (16-Bit Data Length)

The parameter value 1234h shall be written to address 3301 of the inverter.

For that the OUT-data words are set IN THE SAME INTERBUS CYCLE as follows:

OUT1 = B301h (address + write identification), OUT2 = 1234h (data)

After the data is acknowledged by the inverter, the IN-data words change:

IN1 = 3301h (parameter address), IN2 = 1234h (parameter data)

In the case of error the highest bit is set in the 1. IN-word, and in the 2. Inword is the error code:

IN1 = B301h (parameter address + error bit), IN2 = 0003h (errorr 3: invalid data)

Each write procedure is executed only ONCE. In order to write again at least one OUT-data word must be changed (e.g. via the IDLE address).

4.4 Writing a Parameter in the IO-Mode (32-Bit Data Length)

Like writing of 16-Bit data, but OUT2 and OUT3 are interpreted as signaffected data and entered IN THE SAME INTERBUS CYCLE:

Value 8000dec: OUT2 = 0000h; OUT3 = 1F40h

Value -8000dec: OUT2 = FFFFh; OUT3 = E0C0h

4.5 Write with Synchronization in the IO-Mode

The synchronization is only necessary, if, depending on the system, the 1. and 2. or 3. word OUT cannot be transmitted simultaneously to the InterBus host, so that parameter address and parameter data do not appear in the same InterBus cycle. The consequence may be that e.g. the parameter data is transmitted to the previous parameter address or the old parameter data is transmitted to the new parameter address. However, all new InterBus host cards have the possibility to ensure the data consistency, so most likely this procedure has not to be used.

1. Write idle-address 0000h into 1. word OUT.
2. Write parameter data for the parameter into the 2. word OUT (if necessary into the 3. word OUT).
(Are not yet written since the address is 0).
3. Write parameter address with set write-bit into 1. word OUT.
4. Wait until this parameter address appears in the 1. word IN, observe the error bit!
If the error bit is 0, then the data was correctly accepted and the next parameter can be written (continuing with 1).

5 Diagnostic Interface

ATTENTION :

To prevent a destruction of the PC-interface, the diagnostic interface may only be connected to the PC over a special HSP5 cable with voltage adaption.

Over an adapter a HSP5 cable is connected to the diagnostic interface. By way of the PC-software KEB COMBIVIS 5 one has now normal access to all inverter parameters. The operator-internal parameters such as InterBus-process data length and -assignment can also be read and adjusted or parameterized by means of download. Alternatively a monitoring of the InterBus PCP as well as the process data channels can take place with the PC-software KEB protocol monitor.

Separately available accessory

HSP5-cable between PC and adapter: Part.-No.: 00.F5.0C0-0001

Adapter D-Sub9/Western: Part.-No.: 00.F5.0C0-0002

Following operator-parameters for the operation with KEB COMBIVIS 5 are available:

Address	Name	Description
0080h	Date	Indication of the version number. The parameter name also contains the date of the operator firmware. Writable for verification only with the same value.
0081h	Parameter Count	Number of operator parameters. Read-only.
0082h	Response Delay Time	Adjustable time delay for the diagnostic interface.
0083h	Current Password	Display of the current inverter password level. Read-only.
0084h	HSP5_Max_InvBusy_Retries	Adjustment of the number of repetitions at error code 'Inverter Busy'.
0086h	Ext.CommError Counter	Error counter of diagnostic interface. Can be reset by writing.
0087h	HSP5 Tout Count	Error counter of HSP5-interface to the inverter. Can be reset by writing.
008Dh	Synchron Active	Indicates the synchronous operation. 0 = normal, 1 = synchronous active
008Eh	Watchdog Inhibit	See object directory 5FF9h
008Fh	PD_Handshake	See object directory 5FFAh
0090h	PD_Length	See object directory 5FFFh
0091h	PD_In1 Index	Process data assignment like Index 6000h Subindex 2
0092h	PD_In2 Index	Process data assignment like Index 6000h Subindex 6
0093h	PD_In3 Index	Process data assignment like Index 6000h Subindex 10
0095h	PD_In1 Set	Process data assignment like Index 6000h Subindex 3
0096h	PD_In2 Set	Process data assignment like Index 6000h Subindex 7
0097h	PD_In3 Set	Process data assignment like Index 6000h Subindex 11
0099h	PD_In Enable	Process data enabling like Index 5FFEh. When attempting to activate an incorrect process data assignment no error code is returned. Parameter 'Check PD Setting' serves for the testing of the successful assignment.
009Bh	PD_Out1 Index	Process data assignment like Index 6001h Subindex 2
009Ch	PD_Out2 Index	Process data assignment like Index 6001h Subindex 6
009Dh	PD_Out3 Index	Process data assignment like Index 6001h Subindex 10
009Fh	PD_Out1 Set	Process data assignment like Index 6001h Subindex 3
00A0h	PD_Out2 Set	Process data assignment like Index 6001h Subindex 7
00A1h	PD_Out3 Set	Process data assignment like Index 6001h Subindex 11
00A3h	PD_Out Enable	Process data enabling like Index 6002h. When attempting to activate an incorrect process data assignment no error code is returned. Parameter 'Check PD Setting' serves for the testing of the successful assignment.
00A4h	Store Settings	See object directory 5FFCh
00A5h	ProcessData In1	Current value of the 1. process data word IN. Read-only.
00A6h	ProcessData In2	Current value of the 2. process data word IN. Read-only.
00A7h	ProcessData In3	Current value of the 3. process data word IN. Read-only.
00A9h	ProcessData Out1	Current value of the 1. process data word OUT. Read-only.
00AAh	ProcessData Out2	Current value of the 2. process data word OUT. Read-only.
00ABh	ProcessData Out3	Current value of the 3. process data word OUT. Read-only.
00ADh	EE_Address	For the diagnosis of the EEPROM.
00AEh	EE_Data	For the diagnosis of the EEPROM. Read-only.
00AFh	Check PD Setting	Serves for testing the successful process data assignment. During reading the value FFh signals the successful changeover of the process data assignment. A value of 0 indicates a faulty IN- or OUT data assignment. Writing on this parameter with any value returns an OK in case of successful changeover, otherwise it is acknowledged with error code 'Operation not possible' (14).
00B0h	Error Counter Synch	Error counter in the synchronous mode. Only for diagnostic purposes.

6 Operation

6.1 Diagnostic Elements

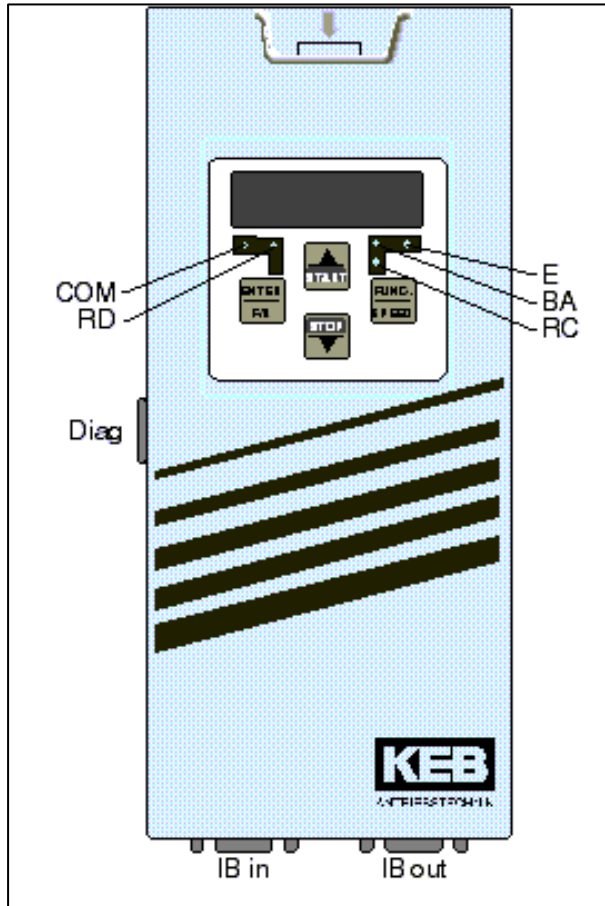

COM (green)
Lights up at communication over InterBus PCP.

RD (red)
On: The outgoing remote bus interface (IB_out) has been switched off by the host

BA (green)
On: InterBus runs
Blinking: InterBus has been stopped by the host.
Off: Remote bus cable either defective or nonexisting / Host not in operation or defective

RC (green)
On: Remote bus ready for operation
Off: Remote bus cable either defective or nonexisting / Host not in operation or defective

E (red)
On: Inverter ready for operation
blinking: Inverter failure
Off: no supply voltage

IB in
Remote bus input (D-Sub 9-plug connector)

IB out
Remote bus output (D-Sub 9- socket)

Diag
Diagnostic interface to the PC

6.2 Connector Pin Assignment

Connector IB in (D-Sub 9pole plug connector)	Connector IB out (D-Sub 9pole socket)
Function: Input IB-2-wire remote bus	Function: Output IB-2-wire remote bus
Pin CN1.1 DI1	Pin CN2.1 DO2
Pin CN1.2 DO1	Pin CN2.2 DI2
Pin CN1.3 Ground1	Pin CN2.3 Ground2
Pin CN1.4 reserved	Pin CN2.4 reserved
Pin CN1.5 reserved	Pin CN2.5 +5V
Pin CN1.6 /DI1	Pin CN2.6 /DO2
Pin CN1.7 /DO1	Pin CN2.7 /DI2
Pin CN1.8 reserved	Pin CN2.8 reserved
Pin CN1.9 reserved	Pin CN2.9 RBST

6.3 Installation

It is absolutely necessary to lay the bus cables separately from the mains or motor cables of the inverter! For further information refer to „Part 1“ of the Instruction Manual KEB COMBIVERT.

Concept

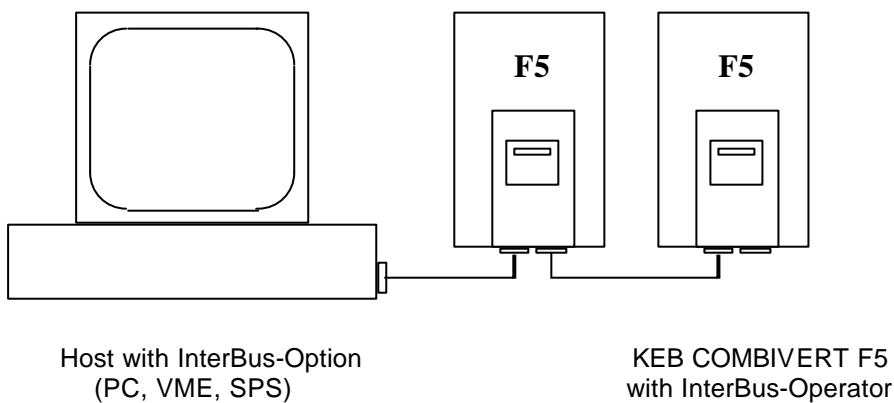

InterBus-2-wire Remote Bus Cable 9-pole/9-pole
 D-Sub 9pole connector D-Sub 9pole socket

Pin 1 (DO2)-----	Pin 1 (DI1)
Pin 2 (DI2)-----	Pin 2 (DO1)
Pin 6 (/DO2)-----	Pin 6 (/DI1)
Pin 7 (/DI2)-----	Pin 7 (/DO1)
Pin 3 (GND)-----	Pin 3 (GND)
Pin 5 (+5V)-----+	
Pin 9 (RBST)----+	
Shield (PE)-----	Shield (PE)



Karl E. Brinkmann GmbH

Försterweg 36 - 38 • D - 32683 Barntrop
Telefon 00 49 / 52 63 / 4 01 - 0 • Fax 00 49 / 52 63 / 4 01 - 1 16
Internet: www.keb.de • E-mail: info@keb.de

KEB Antriebstechnik GmbH & Co. KG

Wildbacher Str. 5 • D - 08289 Schneeberg
Telefon 0049 / 37 72 / 67 - 0 • Telefax 0049 / 37 72 / 67 - 2 81
E-mail: info@keb-combidrive.de

KEB Antriebstechnik Austria GmbH

Ritzstraße 8 • A - 4614 Marchtrenk
Tel.: 0043 / 7243 / 53586 - 0 • FAX: 0043 / 7243 / 53586 - 21
Kostelni 32/1226 • CZ - 370 04 České Budejovice
Tel.: 00420 / 38 / 731 92 23 • FAX: 00420 / 38 / 733 06 97
E-mail: info@keb.at

KEB Antriebstechnik

Herenveld 2 • B - 9500 Geraadsbergen
Tel.: 0032 / 5443 / 7860 • FAX: 0032 / 5443 / 7898
E-mail: koen.detaeye@keb.de

KEB China

Xianxia Road 299 • CHN - 200051 Shanghai
Tel.: 0086 / 21 / 62350922 • FAX: 0086 / 21 / 62350015
Internet: www.keb-cn.com • E-mail: info@keb-cn.com

Société Française KEB

Z.I. de la Croix St. Nicolas • 14, rue Gustave Eiffel
F - 94510 LA QUEUE EN BRIE
Tél.: 0033 / 1 / 49620101 • FAX: 0033 / 1 / 45767495
E-mail: sfkeb.4@wanadoo.fr

KEB (UK) Ltd.

6 Chieftain Buisness Park, Morris Close
Park Farm, Wellingborough, GB - Northants, NN8 6 XF
Tel.: 0044 / 1933 / 402220 • FAX: 0044 / 1933 / 400724
Internet: www.keb-uk.co.uk • E-mail: info@keb-uk.co.uk

KEB Italia S.r.l.

Via Newton, 2 • I - 20019 Settimo Milanese (Milano)
Tel.: 0039 / 02 / 33500782 • FAX: 0039 / 02 / 33500790
Internet: www.keb.it • E-mail: kebitalia@keb.it

KEB - YAMAKYU Ltd.

15 - 16, 2 - Chome, Takanawa Minato-ku
J - Tokyo 108 -0074
Tel.: 0081 / 33 / 445-8515 • FAX: 0081 / 33 / 445-8215
E-mail: kebjt001@d4.dion.ne.jp

KEB Portugal

Lugar de Salgueiros - Pavilhao A, Mouquim
P - 4760 V. N. de Famalicao
Tel.: 00351 / 252 / 371 318 • FAX: 00351 / 252 / 371 320
E-mail: keb.portugal@netc.pt

KEB Taiwan Ltd.

1F, No.19-5, Shi Chou Rd., Tounan Town
R.O.C. - Yin-Lin Hsian / Taiwan
Tel.: 00886 / 5 / 5964242 • FAX: 00886 / 5 / 5964240
E-mail: keb_taiwan@mail.apol.com.tw

KEBCO Inc.

1335 Mendota Heights Road
USA - Mendota Heights, MN 55120
Tel.: 001 / 651 / 4546162 • FAX: 001 / 651 / 4546198
Internet: www.kebco.com • E-mail: info@kebco.com